An aerial photograph of an industrial park at sunset. On the left is a tall, white, lattice-structured water tower. In the center and right are several large, modern industrial buildings with flat roofs and large windows. The background shows a vast green landscape under a bright, low sun.

INDUSTRIAL TRANSITION INSIGHTS
“EFFECT WORKSHOP”
by EnergyVille/Vito
Frank Meinke-Hubeny, 03.12.2021

EnergyVille – Key Expertise Partners

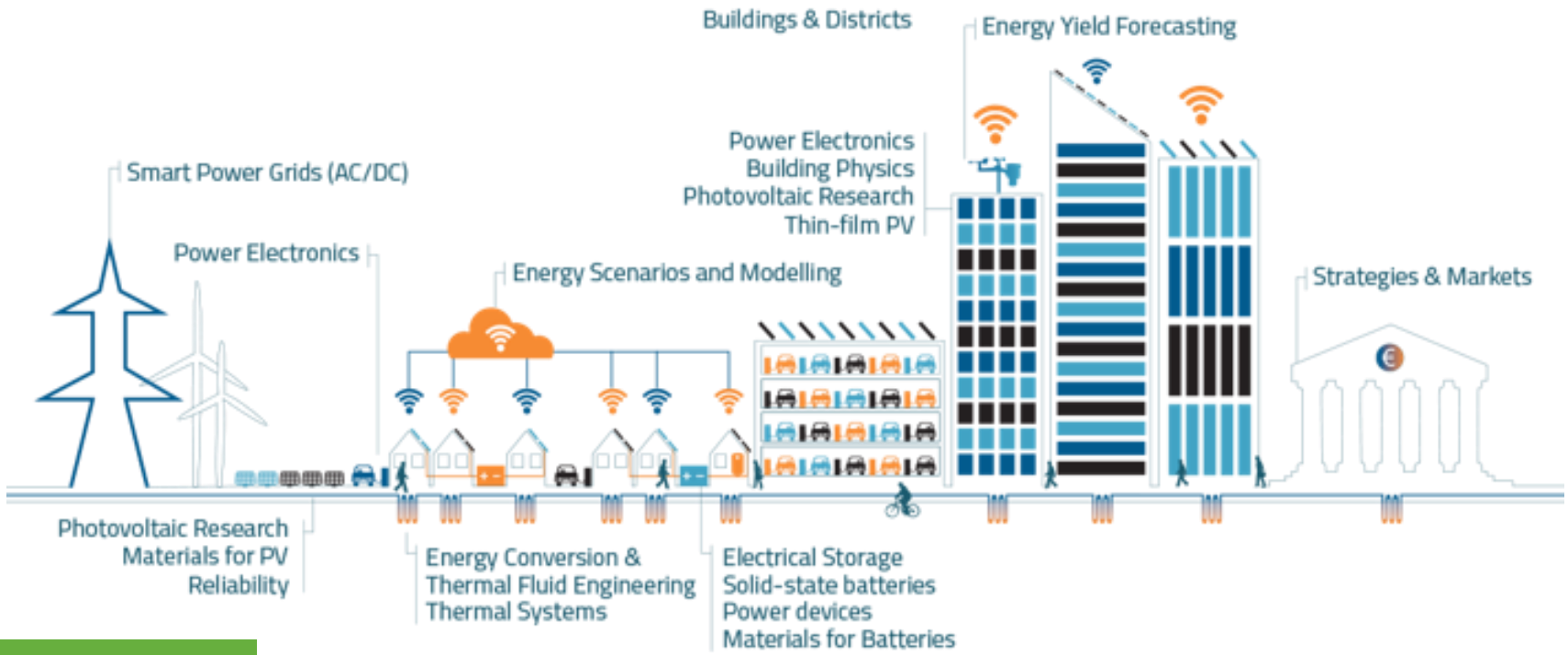

ENERGYVILLE IN FIGURES

NATIONALITIES 2020
40

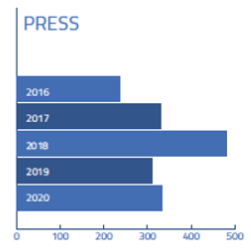
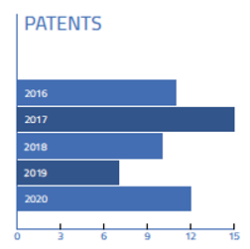
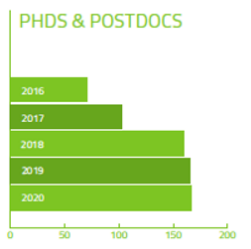
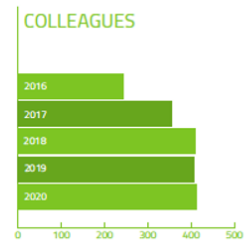

AWARD HIGHLIGHTS

- 2016: ABB Research award Jef Beerten
- 2016: Award for research excellence in district heating and cooling EnergyVille and NODA
- 2017: ERC Grant Bart Vermang
- 2017: Encon Energy Award Thijs Peirelincx
- 2018: Febeliec Energy Award Johan Driesen
- 2018: Encon Energy Award Arthur Schillemans
- 2019: ERC grant Koen Vandewal
- 2020: Encon Energy Award Anne-Claire Legon
- 2020: Sinave award from the Royal Belgian Society for Electricians (KBVE) Willem Leternre
- 2020: BREEAM outstanding certificate EnergyVille 1 building

Research findings on ammonia

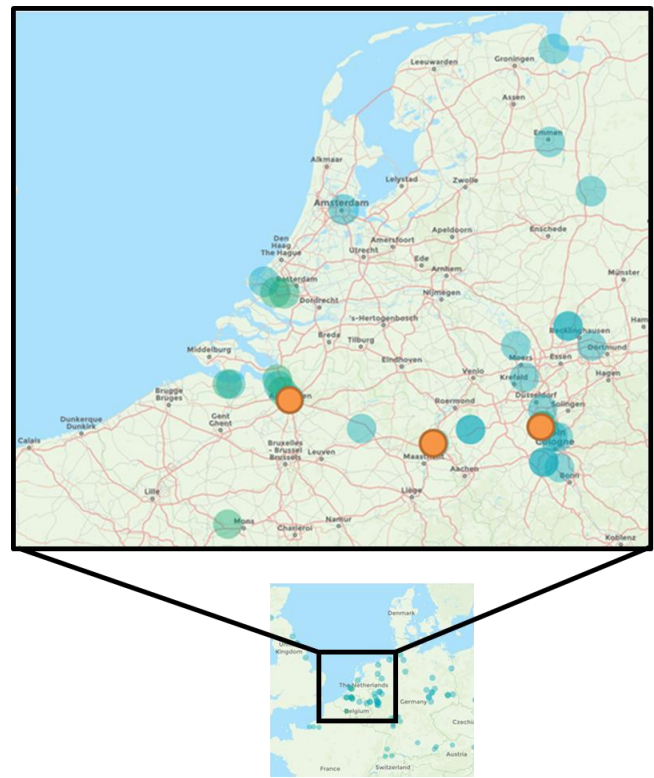

SMR based Ammonia production,
combined ~20% of EU's production

BASF, Antwerp, BE
~600 kton/annum
38% of national natural gas non-energy use

Chemelot site, Geleen, NL
~1100 kton/annum
(urea ~480 kton/annum)
28% of national natural gas non-energy use

CHEMPARK Dormagen, Dormagen, DE
~285 kton/annum
6% of national natural gas non-energy use

INSIGHT 1 - TRILATERAL INFRASTRUCTURE: BE-NL-NRW (DE)

4 Carbon-neutral pathway scenarios exist for SMR based ammonia

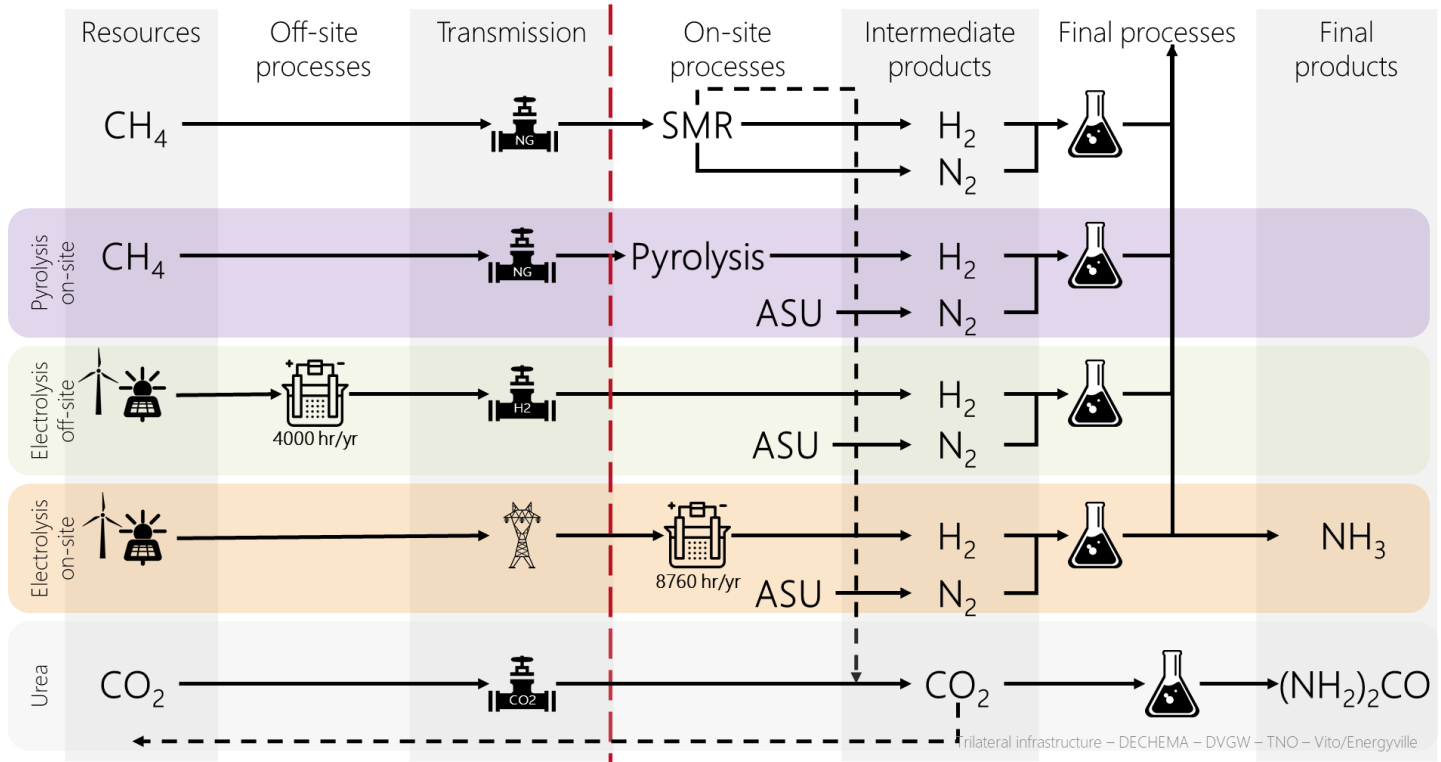

INSIGHT 1 - TRILATERAL INFRASTRUCTURE: BE-NL-NRW (DE)

Model: Evolution of key drivers & projection assumptions

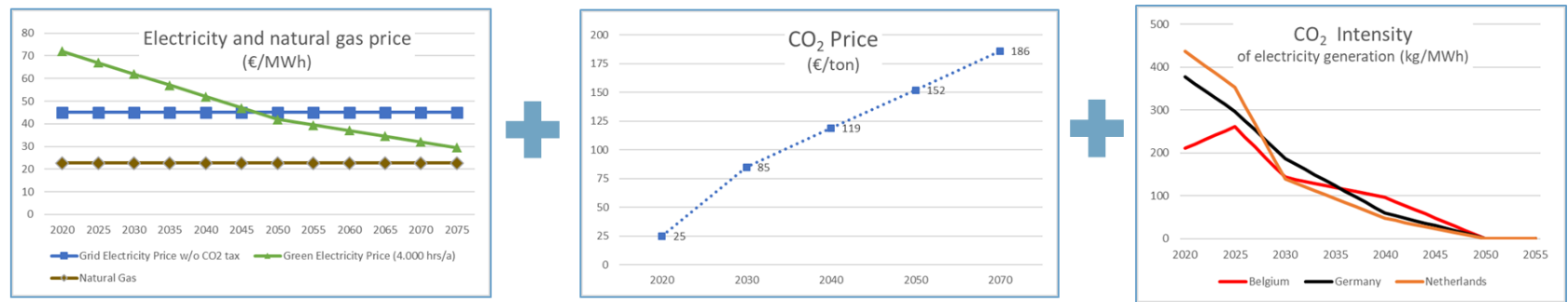

Improvements of installations:
CAPEX, OPEX, efficiency, ...

SMR
Pyrolysis
ASU

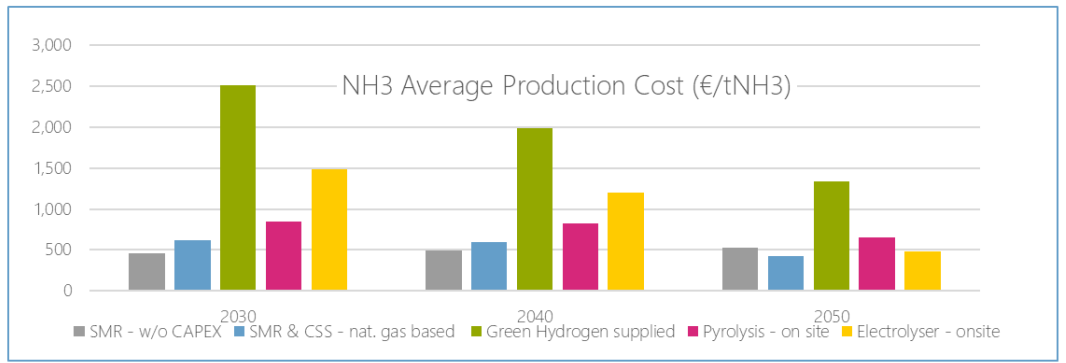

Site specific insights for each pathway – example Chemelot (NL)

- › Impact on CO₂
 - › On-site SMR-CCS requires a CO₂ pipeline with a capacity of roughly 1.3 Mton/a
 - › All other pathways lead to negative emissions and requires 0.35 Mton/a CO₂ transport to the site as feedstock for urea
- › Impact on energy carriers
 - › Pyrolysis requires increase of natural gas transport capacity up to 81 PJ/a (+6.4%** of Dutch national gas consumption)
 - › Electrolysis off-site requires a hydrogen pipeline with a capacity of 185 kton/a (in scope of Gasunie's hydrogen backbone)
 - › Electrolysis on-site would require a 11 TWh/a power connection (+20%** Dutch industrial electricity consumption)

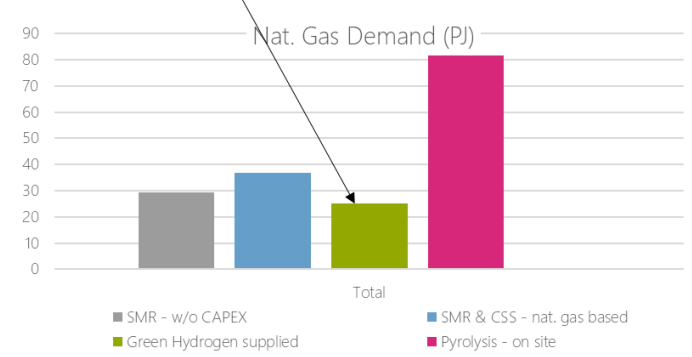
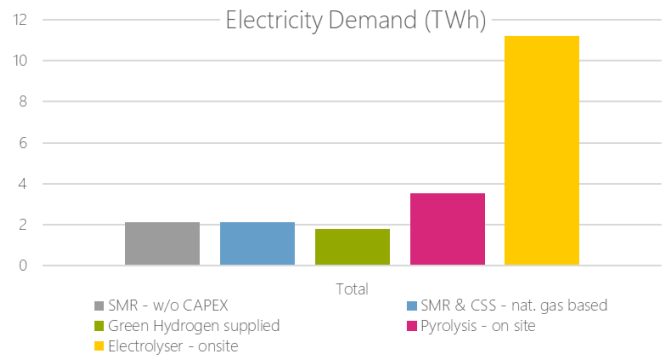

**Based on CBS data obtained from www.energiein nederland.nl, accessed April 2020

Overview of site-specific aspects

	Antwerp (BE)	Dormagen (DE)	Geleen (NL)	comments
Conventional	Existing Production	Existing Production	Existing Production	
SMR + CCS (blue H ₂)	Harbor location advantageous for CO ₂ export via shipping	CCS currently not possible in Germany	Offshore storage potential in empty gas fields	CO ₂ -infrastructure required -> repurposing NG pipelines
Green H ₂ (pipeline or shipping)	Hydrogen pipeline but limited capacity; Harbor location with potential for direct H ₂ terminal	Hydrogen pipeline but no connection to port	Natural gas pipelines could be converted to hydrogen	Existing hydrogen infrastructure not sufficient
Electrolysis on-site	Coastal location could lead to easy access to North Sea offshore wind park,	Good grid connection (Power plant on-site, powered by natural gas)	Existing transmission network from coast to site, although far from shore	May be limited by grid capacity and large amount of green electricity (offshore?)
	6 TWh/a would require cross-border grid improvement		11 TWh/a would require grid improvement to site	
Pyrolysis of natural gas	Strong natural gas connection	Natural gas connection with 320 000 cubic meters per hour sufficient	Existing gas infrastructure insufficient	Continuous natural gas supply required

TRILATE - Industrial Transition Project (2021 – 2024)

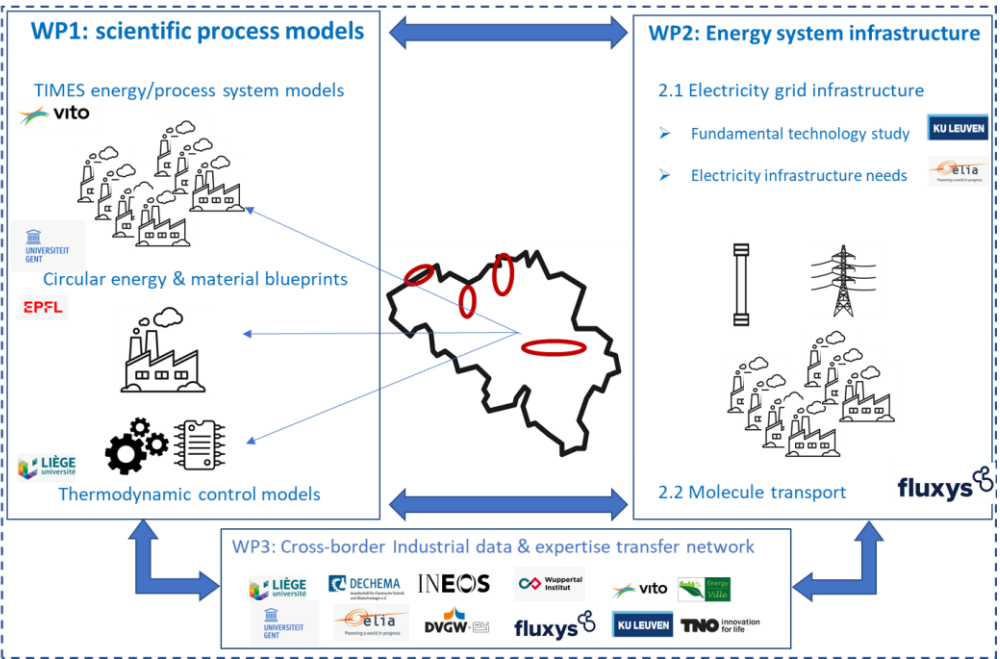

Funded Linkage to DE & NL



Interested to join the exchange? Let us know!

Goal & Result

“Advancing industrial decarbonization by assessing the future use of renewable energies in industrial processes”

Service, i.e. data visualization, to the EC in carrying out an analysis to understand the effectiveness, efficiency and cost of **potential innovation pathways** for achieving carbon neutral processes in six sectors:



Data base input for ...

- Energy and Industry Geography Lab (EIGL) -> JRC
- Follow-up energy system modelling (EC – DG ENER)

3. AIDRES – MAPPING & OVERVIEW



AIDRES



IPES
Industrial Process
and Energy Systems
Engineering



EII's production sites EU 27 by sector

- Steel
- Cement
- Glass
- Chemical
- Fertilisers
- Refineries
- EU27

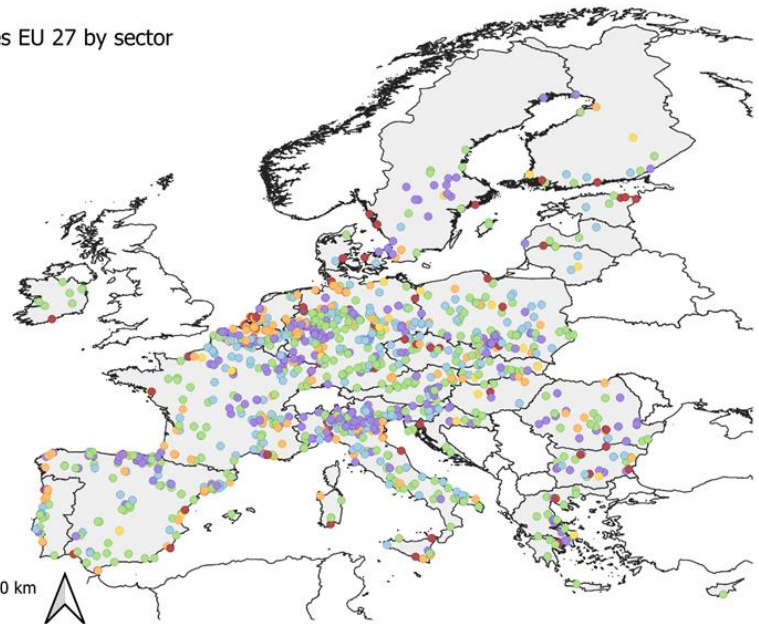
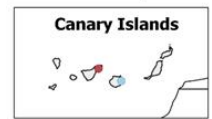

Sector	#Production sites
Steel	372
Refinery	112
Cement	436
Glass	319
Chemical	258
Fertilisers	39
Total	1536

A **production site** is the geographical unit that combines production installations from one sector and specific company in space. E.g., a chemical production site (BASF Ludwigshafen) can group more than 40 production installations from the chemical sector at one site.

3. AIDRES – INVENTORY OF INDUSTRIAL PARAMETERS - APPROACH



AIDRES



Result Task 1: AIDRES database with all EU27 production sites classified per sector

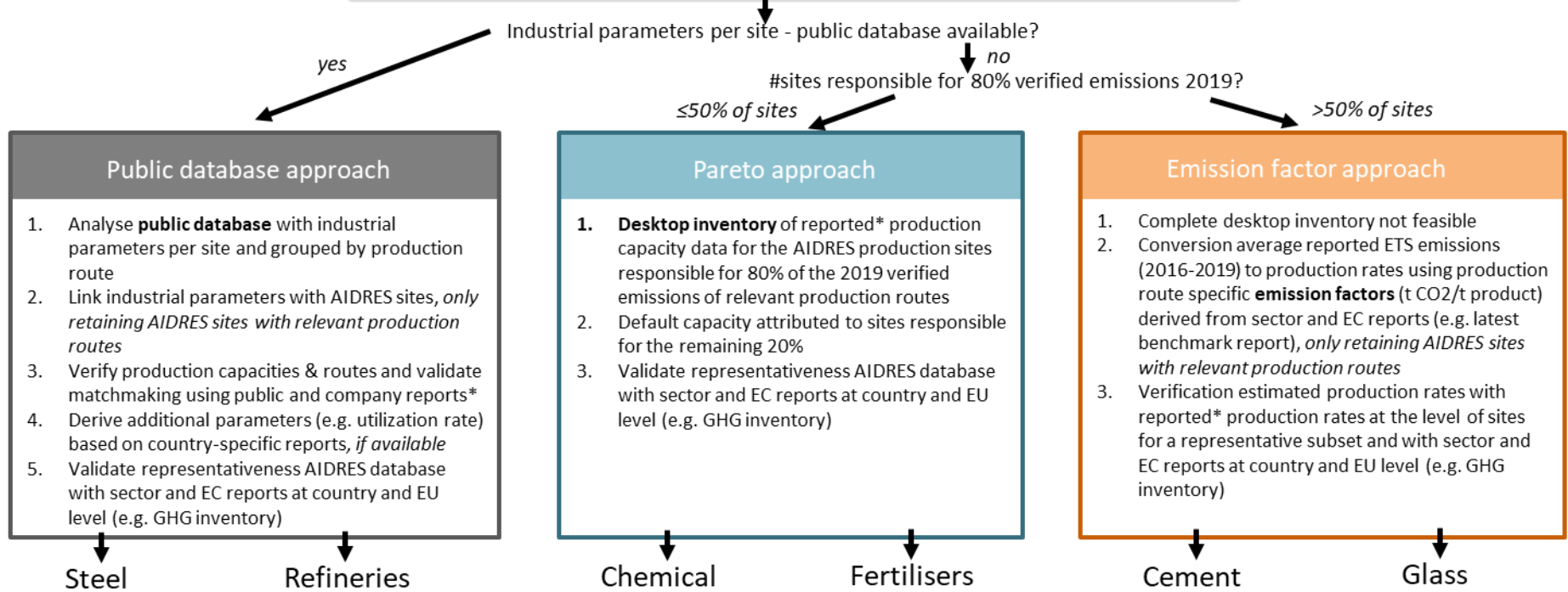

3. AIDRES – PROJECT PLAN OVERVIEW



AIDRES

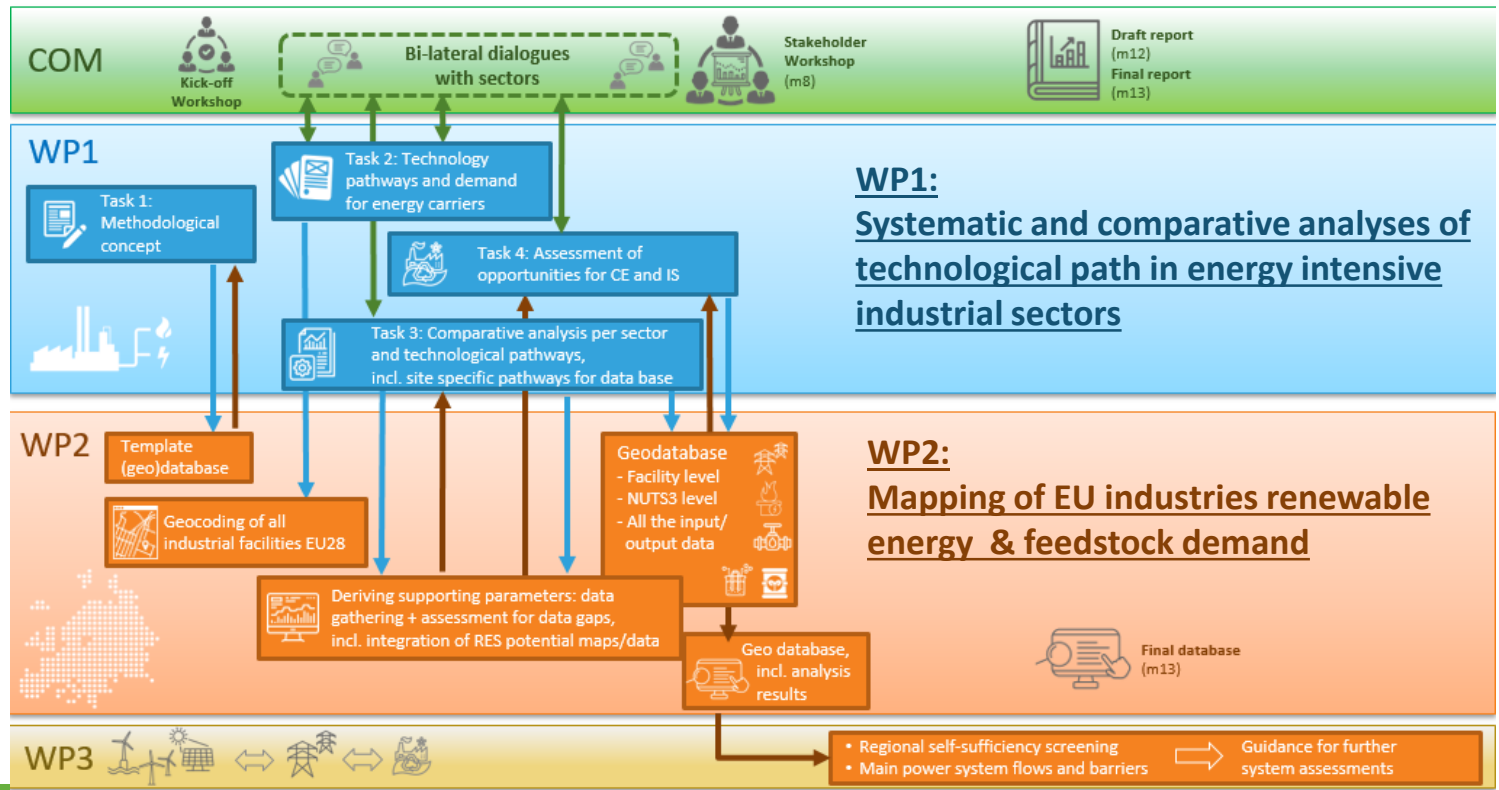

Months	1	2	3	4	5	6	7	8	9	10	11	12	13	14	15	16
--------	---	---	---	---	---	---	---	---	---	----	----	----	----	----	----	----

▪ Next steps ...

- Calculation on NUTS 3 level for energy and feedstock needs
 - 2030 & 2050
- 'Pre-selected' scenarios derived from EC 'Fit for 55' publications (July 2021)
 - (ETS) CO₂ price
 - H₂ (import) price
 - Elc price & carbon content
 - Fossil fuel prices
- Industrial symbiosis within NUTS 3 region (link to EPOS and SPIRE projects)
 - Exchange of heat
 - Exchange of materials
- **Data base foreseen in Feb 2022 => Push to make it available!**



... keep in touch!

Frank Meinke-Hubeny

Sr. Researcher | Project Manager – Sustainable Energy
Unit Smart Energy & Built Environment

HQ: VITO NV | Boeretang 200 | BE-2400 Mol

Office: EnergyVille I | Thor Park 8310 | BE-3600 Genk

Phone +3214335820 | Frank.Meinke-Hubeny@vito.be

